

Key Features

- Simplify wiring, reduce cost through the onboard dual-port Ethernet switch
- Industry Standard CiA 402 Motion Profile support
 - PP, PV, HM, TQ, CSP, CSV, and CST modes
- Dynamic Mapping of Process Data Objects (Cyclic Data Exchanges)
- Real time coordinated control using Distributed Clock (DC)
- Optionally program, configure and get live diagnostics through the USB interface
- Optionally communicate with the motor through the RS-485 half-duplex port, which provides access as a Modbus Remote Terminal Unit (RTU) Slave
- Easily access SmartMotor™ programmable autonomous control features in slave mode, which allows special user-programmed functions
 - Reduce limit switch wiring and PLC programming through adaptable distributed control
 - Accurately capture position for high-speed registration applications
 - Quickly reduce costs and improve reliability through use of programmable homing and limits
 - Precisely define motion profiles with local cam execution
 - Easy configuration and status monitoring of Industrial Ethernet and field buses
 - Actively monitor/troubleshoot each motor through local error reporting and diagnostic codes
- Local/standalone benefits (see manual for details):
 - Simplify programming and calculate 32-bit precision motion parameters on-the-fly with floating-point math and trigonometric functions
 - Govern a move by running it on top of a gearing or camming relationship using the dual-trajectory generators
 - Create precise spooling/winding shapes and control tension through advanced gearing (supports preset traverse/take-up parameters)
 - Create complex patterns through advanced camming (with cubic spline interpolation and dynamic frequency/amplitude)
 - Highly configurable local I/O for motion control and general-purpose use in user programs:
 - Drive enable input, fault output, travel limits, registration and position capture
 - External encoder input supporting A-quadr-B or Step-and-Direction
 - Total of 7 configurable inputs
 - High-current outputs with external brake-control function



Specifications at 25°C

SmartMotor™ Series	SM23216MH-EEC	
Continuous Torque at 48 volts	165	oz-in
	1.17	N-m
Peak Torque	300	oz-in
	2.12	N-m
Nominal Continuous Power	60	watts
Nominal Peak Power	115	watts
No Load Speed	2,250	rpm
Encoder Resolution	4,000	counts/rev
Weight	1.70	lb
	0.77	kg
Shaft Diameter	0.394	in
	10.00	mm
Shaft, Radial Load	15.00	lb
	6.80	kg
Shaft, Axial Thrust Load	3.00	lb
	1.36	kg

Maximum temperature: 85°C at electronics, 130°C at windings
 Recommended ambient temperature range: 0°C – 50°C
 Storage temperature range: -10°C – 85°C
 Relative humidity: maximum 90%, noncondensing

Power Chart

SM23216MH-EEC motor Torque vs. Speed, 48 volts, MDC commutation, 25°C ambient (curves are derated at higher ambient)

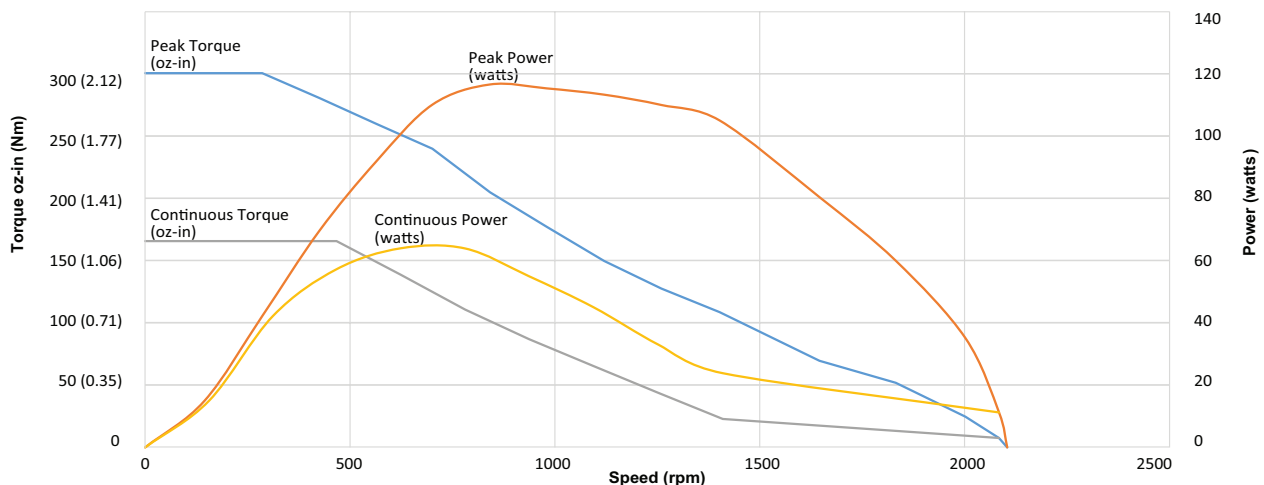

Continuous rating based on 25°C ambient temperature, motor mounted to a 6x6x¼ inch aluminum heat sink, and electronics/windings below maximum temperature. Peak torque is available for 3 seconds at a 10% duty cycle.

Dimensional Information

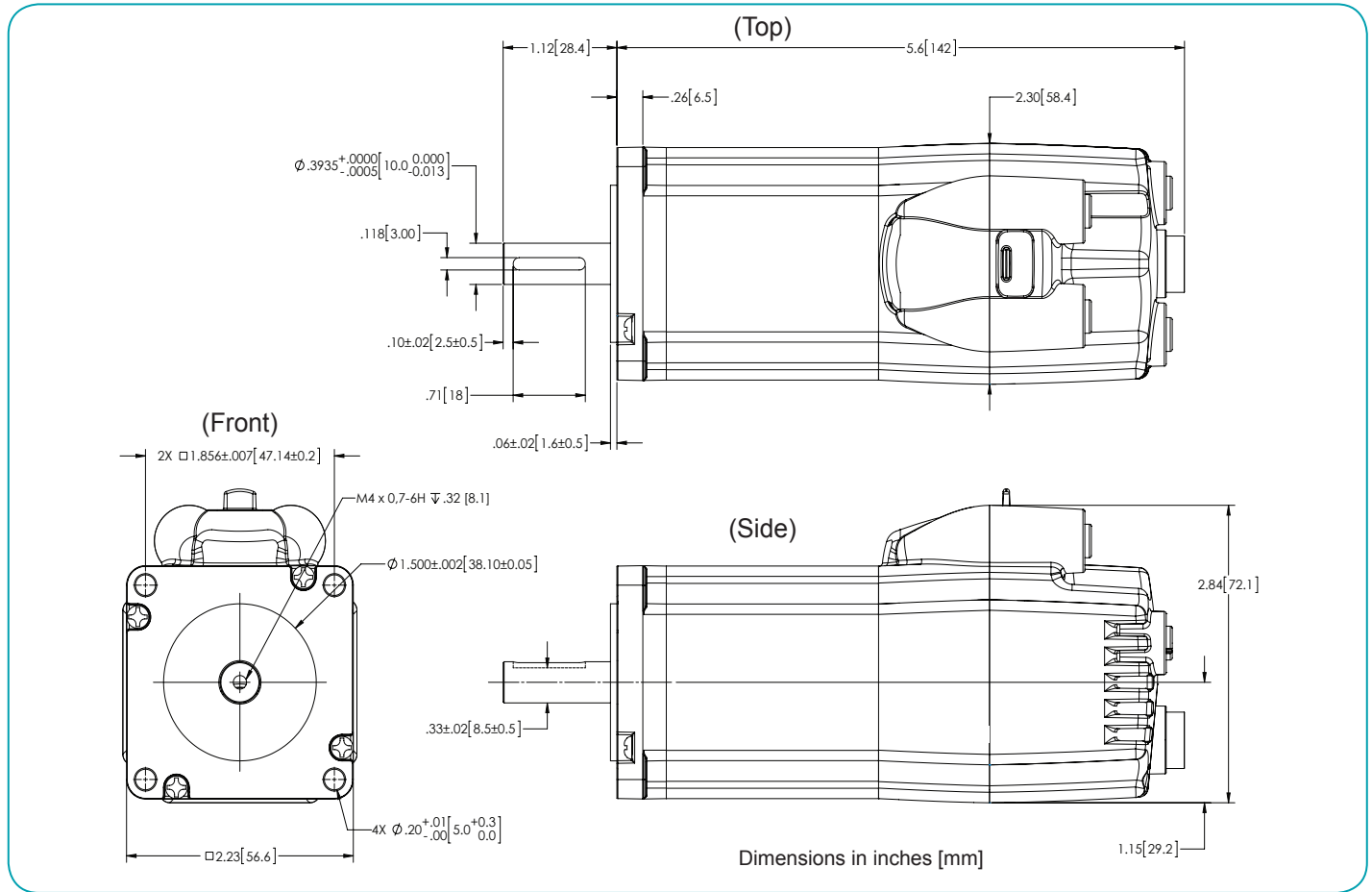

Connections

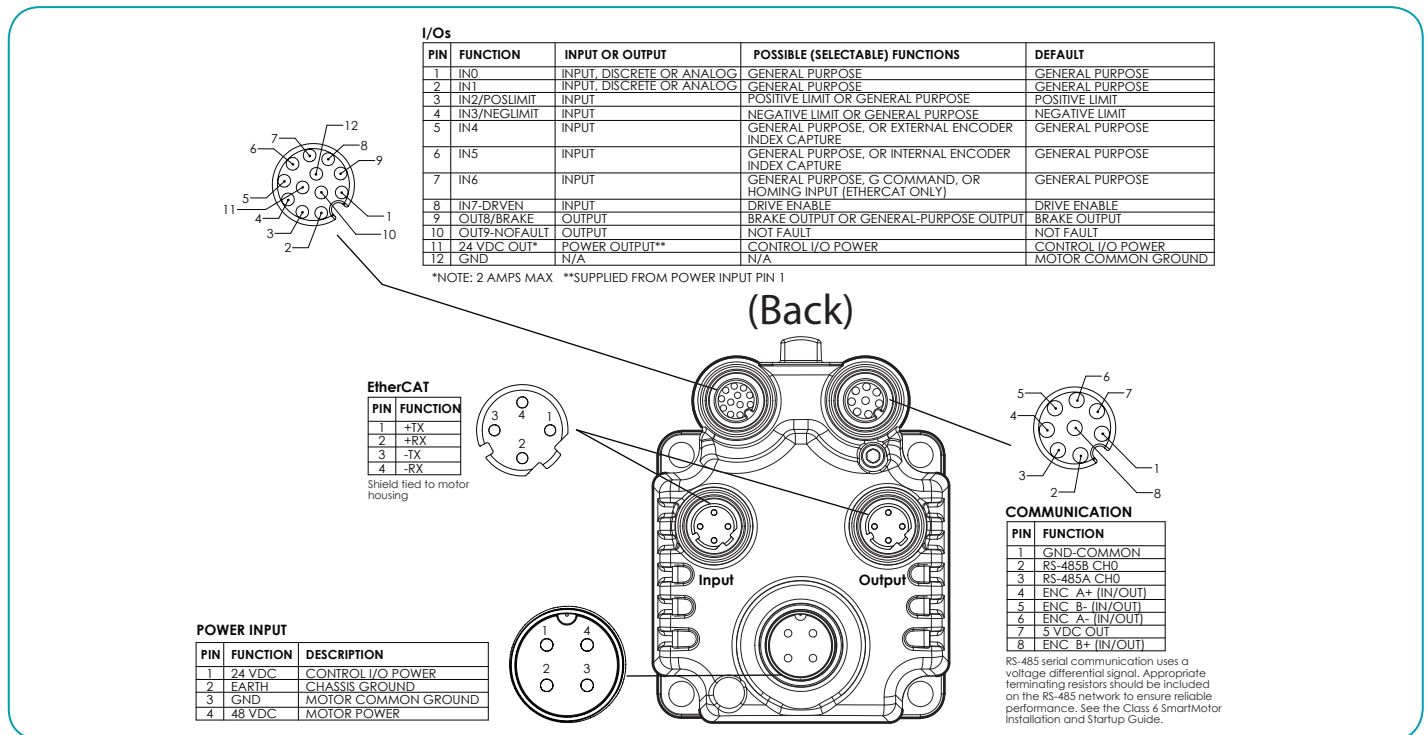

Specifications are subject to change without notice. Consult website and factory for latest data.